

1. Module detail and its structure

Subject Name	Physics
Course Name	Physics 03 (Physics Part 1 Class XI)
Module Name/Title	Unit-04,Module-01: Electromagnetic induction Chapter-06: Electromagnetic Induction
Module Id	Leph_10601_eContent
Pre-requisites	Concept of magnetism, magnetic field ,area vector
Objectives	<p>After going through this module, the learners will be able to:</p> <ul style="list-style-type: none"> • Understand the phenomenon of electromagnetic induction • Appreciate Faraday’s experiments on electromagnetic induction • Correlate the idea of Magnetic flux with electric flux • Distinguish between magnetic field and magnetic flux • State and explain Faraday’s laws of electromagnetic induction
Keywords	electromagnetic induction, magnetic flux , area vector , Faraday’s laws ,Faraday’s experiments

2. Development team

Role	Name	Affiliation
National MOOC Coordinator (NMC)	Dr. AmarendraBehera	Central Institute of Educational Technology, NCERT, New Delhi
Programme Coordinator	Dr.Mohd Mamur Ali	Central Institute of Educational Technology, NCERT, New Delhi
Course Coordinator / PI	Anuradha Mathur	Central Institute of Educational Technology, NCERT, New Delhi
Subject Matter Expert (SME)	Taru Goyal	Air Force Sr. Sec. School OWC, Race Course, New Delhi.
Review Team	Associate Prof. N.K. Sehgal (Retd.) Prof. V. B. Bhatia (Retd.) Prof. B. K. Sharma (Retd.)	Delhi University Delhi University DESM, NCERT, New Delhi

TABLE OF CONTENTS

1. Unit Syllabus
2. Module wise distribution
3. Words you must know
4. Introduction
5. What is Electromagnetic induction?
6. Experiments of Faraday and Henry
7. Magnetic Flux
8. Unit of magnetic flux
9. Cause of induced emf
10. Faraday's laws of electromagnetic induction
11. Summary

1. UNIT SYLLABUS

Unit IV: Electromagnetic Induction and Alternating Currents: 9 modules

Chapter-6: Electromagnetic Induction

Electromagnetic induction; Faraday's laws, induced emf and current; Lenz's Law, Eddy currents; Self induction and mutual induction.

Chapter-7: Alternating Current

Alternating currents, peak and rms value of alternating current/voltage; reactance and impedance; LC oscillations (qualitative treatment only), LCR series circuit, resonance; power in AC circuits, wattless current. AC generator and transformer.

2. MODULE WISE DISTRIBUTION OF UNIT SYLLABUS

09 Modules

The above unit is divided into nine modules for better understanding.

Module 1	<ul style="list-style-type: none"> • Electromagnetic induction • Faraday's laws, induced emf and current; • Change of flux • Rate of change of flux
Module 2	<ul style="list-style-type: none"> • Lenz's Law, • Conservation of energy • Motional emf
Module 3	<ul style="list-style-type: none"> • Eddy currents. • Self induction • Mutual induction. • Unit <p>Numerical</p>
Module 4	<ul style="list-style-type: none"> • AC generator • Alternating currents, • Representing ac <ul style="list-style-type: none"> ✓ <i>Formula</i> ✓ <i>Graph</i> ✓ <i>Phasor</i> • Frequency of ac and what does it depend upon • peak and rms value of alternating current/voltage;
Module 5	<ul style="list-style-type: none"> • AC circuits • Components in ac circuits • Comparison of circuit component in ac circuit with that if used in dc circuit • Reactance <ul style="list-style-type: none"> ✓ <i>pure R</i> ✓ <i>pure L</i>

	<ul style="list-style-type: none"> ✓ <i>Pure C</i> • Phasor, graphs for each
Module 6	<ul style="list-style-type: none"> • AC circuits with RL, RC and LC components • Impedance; LC oscillations (qualitative treatment only), • Resonance • Quality factor
Module 7	<ul style="list-style-type: none"> • Alternating voltage applied to series LCR circuit • Impedance in LCR circuit • Phasor diagram • Resonance • Power in ac circuit • Power factor • Wattles current
Module 8	<ul style="list-style-type: none"> • Transformer
Module 9	<ul style="list-style-type: none"> • Advantages of ac over dc • Distribution of electricity to your home

MODULE 1

3. WORDS YOU MUST KNOW

Let us remember the words we have been using in our study of this physics course:

- **Magnetic field:** The region around a magnet, within which its influence can be felt, denoted by B
- **Magnetic flux:** Intuitive way of describing the magnetic field in terms of field lines crossing a certain area in a magnetic field. Magnetic flux is defined in the same way as electric flux is defined. Magnetic flux through a plane of area A placed in a uniform magnetic field B , denoted by ϕ_B
- **Electric cell** a simple device to maintain a steady current in an electric circuit is the electrolytic cell
- **Electromotive Force e :** The amount of work done by a cell (the amount of energy provided by the cell) , to take a unit charge once round the circuit. e is, actually, a potential difference and *not a force*. The name emf, however, is used because of historical reasons, and was given at a time when the phenomenon was not understood properly.
- **Area vector:** A vector perpendicular to a given area whose magnitude is equal to the given area.
- **Ampere:** It is the unit of current.
- **Volt:** It is the unit of emf and potential difference.

4. INTRODUCTION

Electricity and magnetism were considered separate and unrelated phenomena for a long time. In the early decades of the nineteenth century, experiments on electric current by Oersted, Ampere and a few others established the fact that electricity and magnetism are inter-related. They found that moving electric charges produce magnetic fields. For example, an electric current deflects a magnetic compass needle placed in its vicinity.

The experiments of Michael Faraday in England and Joseph Henry in USA, conducted around 1830, demonstrated conclusively that electric currents were induced in closed coils when subjected to changing magnetic fields.

We will study the phenomena associated with changing magnetic fields and understand the underlying principles.

WHAT IS INDUCTION?

Temporary change in any condition (effect) due to a cause in the vicinity (near). The change lasts as long as the cause is present.

Example In Electrostatic Induction:

temporary separation of charges (+ve and –ve) in materials whenever a charged body is brought near it, the separation lasts only till the charged body is placed near the body.

Bits of paper are attracted by charged glass /plastic rods.

Also Magnetic induction will take place whenever a magnet is brought close to a material; Ferro magnetic substances show more induction and are attracted towards the magnet.

Both poles of a magnet can attract iron nails.

Notice in both electrostatic and magnetic induction the effect lasts only till the cause (charged rod or magnet) is held near the uncharged /magnetic material.

The phenomenon in which, electric current is induced in conductors by varying magnetic fields around it, is appropriately called **electromagnetic induction**.

So we will answer questions such as:

- If moving charges produced magnetic field and the magnetic field existed so long as the charge was moving, then is the reverse statement ‘moving’ or ‘changing magnetic field’, will give rise to currents?
- If yes, then can it be experimentally established?
- What could be the different ways of showing production of electric current by changing magnetic fields?

5. WHAT IS ELECTROMAGNETIC INDUCTION?

We have seen, in earlier chapters that

- **Moving charges produce magnetic fields.**
- **A current carrying wire can deflect a magnetic compass.**

A very obvious question that comes to our mind is that whether the reverse is also true, that is can a moving magnet also produce an electric current?

The phenomenon, in which electric current can be generated by varying magnetic fields, is called electromagnetic induction (EMI).

The emf developed is called **induced emf**; when the conductor is in the form of a closed loop, and the induced emf will cause a current to flow, the current developed in the loop is called **an induced current**.

The phenomenon of electromagnetic induction is the basis of working of devices like the generators, dynamos, transformers etc.

These are the devices which form the backdrop of production and distribution of electricity. Without electricity, we cannot imagine our world now; therefore, the concept of EMI is of utmost importance for all of us.

6. EXPERIMENTS OF FARADAY AND HENRY

The discovery and understanding of the phenomenon of electromagnetic induction are based on a long series of experiments carried out by Faraday and Henry. We shall now discuss some of these experiments.

Experiment 1: Current induced by a magnet

Demonstration setup: Let us take a coil C_1 connected to a galvanometer G .

Wherever the term 'coil or 'loop' is used, it is assumed that they are made up of conducting material and are prepared using wires which are coated with insulating material.

Normally, in such a set up the meter would not deflect as there is no source of emf.

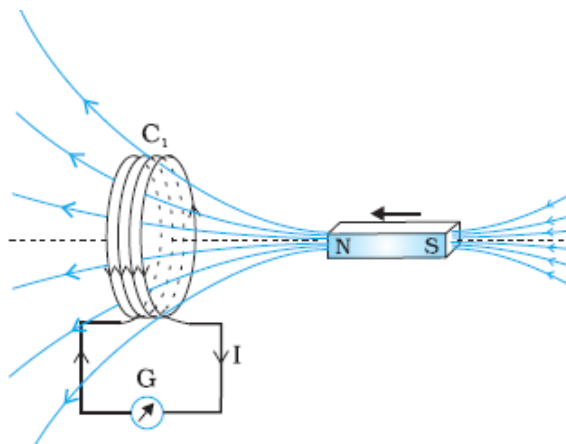

Figure shows When the bar magnet is pushed towards the coil, the pointer in the galvanometer G deflects.

Now if we move a bar magnet towards the coil the galvanometer shows a (momentary) deflection. **There is a (momentary) current in the coil; this current is called an induced current due to the induced emf.**

WHAT IF

The bar magnet tied at the centre , was suspended like a pendulum, and allowed to oscillate?

Observations:

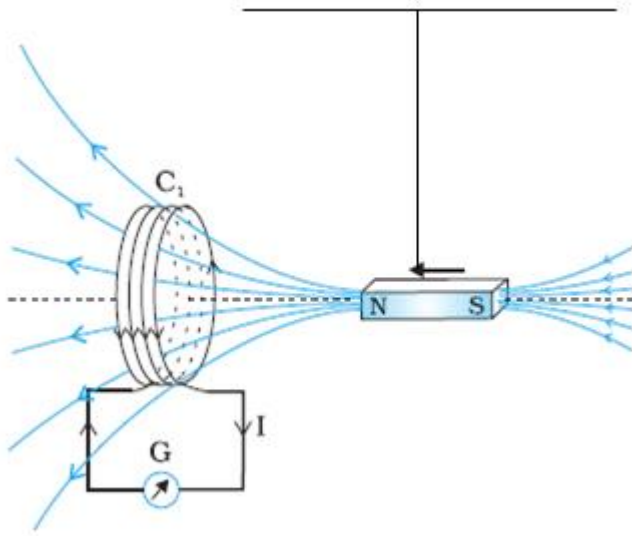

Figure shows the oscillating magnet changing the magnetic flux around the coil

- When the North-pole of a bar magnet is pushed towards the coil, the pointer in the galvanometer deflects, indicating the presence of electric current in the coil.
- The deflection lasts as long as the bar magnet is in motion. The galvanometer does not show any deflection when the magnet is held stationary.
- When the magnet is pulled away from the coil, the galvanometer shows deflection but now in the **opposite direction**; this indicates a reversal of the current's direction.
- When the South-pole of the bar magnet is moved towards or away from the coil, the deflections in the galvanometer are opposite to that observed with the North-pole for similar movements.
- The deflection (and hence current) is found to be larger when the magnet is pushed towards, or pulled away, from the coil at a **faster rate**.
- When the bar magnet is held fixed, and the coil C_1 is moved towards, or away from the magnet, similar effects are again observed.
- What will happen when the bar magnet suspended by a thread is moved like a pendulum?

CONCLUSION:

The experiment shows that it is the presence of a **relative motion, between the magnet and the coil** that is responsible for the generation (induction) of electric current in the coil.

Let us take a look at the following simulations to have a better understanding:

EXPERIMENT 2: CURRENT INDUCED BY ANOTHER CURRENT

Demonstration setup: The bar magnet is replaced by a second coil C_2 connected to a battery. The steady current, in coil C_2 , produces a steady magnetic field.

Experiment and Observations:

- As coil C_2 is moved towards the coil C_1 , the galvanometer shows a deflection. This indicates that electric current is induced in coil C_1 .
- When C_2 is moved away, the galvanometer shows a deflection again, but this time in the opposite direction.

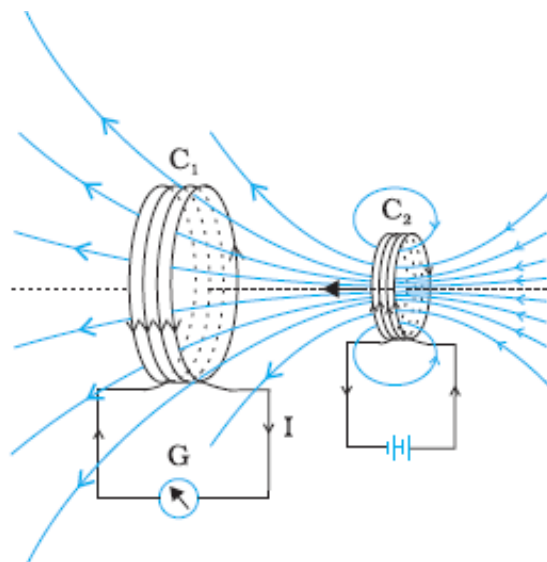

Figure shows Current is induced in coil C_1 due to motion of the current carrying coil C_2 .

- The deflection lasts as long as coil C_2 is in motion.
- When the coil C_2 is held fixed and C_1 is moved, similar effects are again observed.

CONCLUSION: It is the relative motion between the two coils ('set-up' as shown) that induces an electric current.

EXPERIMENT 3: CURRENT INDUCED BY A CHANGING CURRENT

Demonstration setup: Two coils C_1 and C_2 held stationary. Coil C_1 is connected to galvanometer G while the second coil C_2 is connected to a battery through a tapping key K .

Experiment and Observations:

- The galvanometer shows a momentary deflection when the tapping key K is just pressed.
- If the key is kept pressed continuously, there is no deflection in the galvanometer.
- When the key is released, a momentary deflection is again observed, it is, however, in the opposite direction.

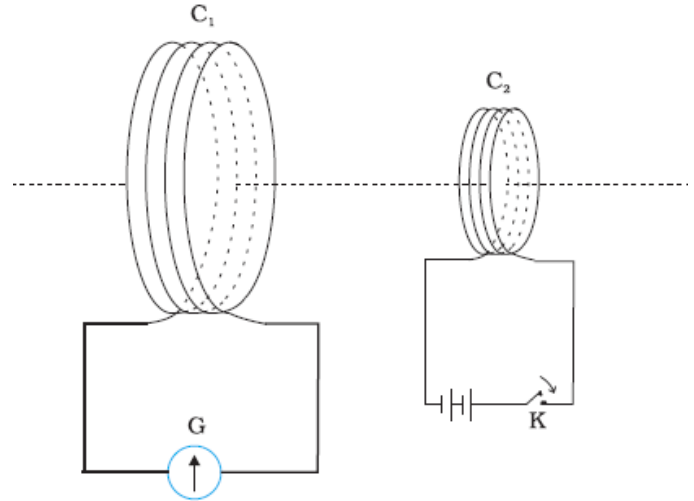

Figure shows experimental set-up for experiment

- The deflection increases significantly when an iron rod is inserted into the coils along their axis.

CONCLUSIONS:

Through this experiment it can be concluded that relative motion is not an absolute requirement for getting an induced current; a current can be induced by changing the current in the neighboring coil.

BUT when you think of it- the changing current will produce changing magnetic field around it. So the coil C_1 must have a changing magnetic field around it.

SO the changing magnetic field around a conductor coil, may be due to

- **moving magnet around it ,**
- **moving coil in a fixed magnetic field or**
- **changing current in the coil near the current loop**
- **changing current in the coil itself**

Can you think of more ...

7. MAGNETIC FLUX

In order to appreciate the findings of Faraday's experiments mathematically we need to understand the term 'magnetic flux'. Just like electric flux, magnetic flux Φ_B , through any surface of area A , held in a magnetic field \mathbf{B} is given by the total number of magnetic field lines crossing the area. Mathematically, it is equal to the dot product of \mathbf{B} and \mathbf{A} .

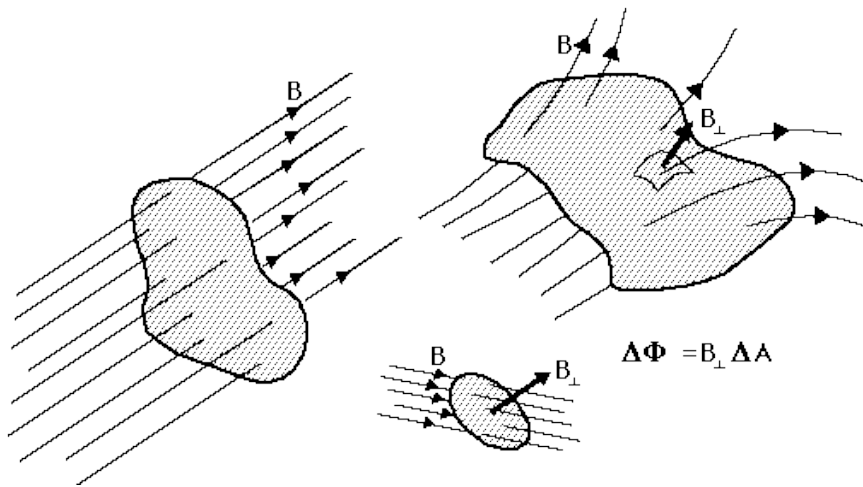

$\Phi_B = \mathbf{B} \cdot \mathbf{A} = B A \cos \theta$, where θ is the angle between \mathbf{B} and \mathbf{A} .

The above diagram shows the relevance of area vector to describe flux.

Flux through a surface area depends upon:

- Strength \mathbf{B}
- Area A
- Angle between \mathbf{B} and \mathbf{A}

If the magnetic field has different magnitudes and/or directions at various parts of a surface, the magnetic flux through the surface is given by:

$$\Phi_B = B_1 \cdot dA_1 + B_2 \cdot dA_2 + \dots = \sum_{\text{all}} B_i \cdot dA_i = \int \mathbf{B} \cdot d\mathbf{A}$$

Here, 'all' stands for summation over all the area elements $d\mathbf{A}_i$ comprising the given surface and \mathbf{B}_i is the magnetic field at the area element $d\mathbf{A}_i$. The integration is over the entire area.

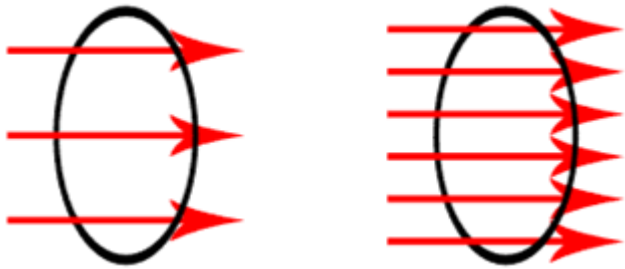

Flux is proportional to the density of field lines per unit area held perpendicular to the field lines .



Flux varies according to the angle area vector A makes with the field lines

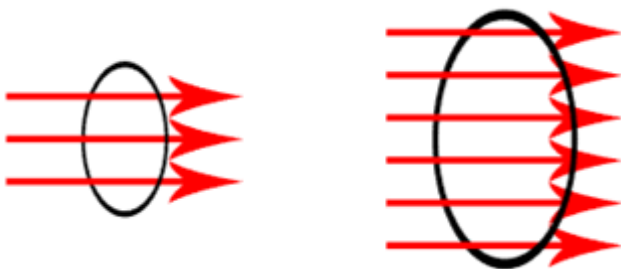

Flux is maximum when the angle between area vector and B is zero

Magnetic flux is a scalar quantity.

When the surface is parallel to the magnetic field then the area vector will be perpendicular to the magnetic field and $\Theta=90^\circ$.

$$\phi = B A \cos 90 = 0$$

When the surface is perpendicular to the magnetic field then the area vector will be parallel to the magnetic field and $\Theta = 0^\circ$.

$$\phi = B A \cos 0 = BA$$

It is the maximum value

When a coil of N turns, each of area A , is held in a magnetic field of strength \mathbf{B} , magnetic flux, associated with the coil, is given by:

$$\Phi_B = N (\mathbf{B} \cdot \mathbf{A}) = NBA \cos \theta ,$$

where θ is the angle between the direction of \mathbf{B} and the normal to the surface area of the coil or the area vector \mathbf{A}

8. UNIT OF MAGNETIC FLUX

The SI unit of magnetic flux is weber (Wb) or Tesla meter square (Tm^2).

One weber is defined as amount of magnetic flux over an area of 1m^2 held normal to a uniform magnetic field of one tesla.

The cgs unit of magnetic flux is maxwell (Mx), where $1\text{wb}=10^8\text{Mx}$.

The dimensional formula of magnetic flux is $\Phi_B = (F/qv) A \cos\Theta =$

$$[\text{MLT}^{-2}][\text{L}^2] / [\text{AT}][\text{LT}^{-1}] = [\text{ML}^2\text{T}^{-2}\text{A}^{-1}]$$

9. CAUSE OF INDUCED EMF

Faraday arrived at the conclusion: **“An emf is induced in a conductor whenever the magnetic flux through it changes with time”**.

Experimental observations, discussed above can be explained by using this concept.

Experiments 1 and 2: The motion of a magnet towards or away from coil C_1 in Experiment 1 and moving a current-carrying coil C_2 towards or away from coil C_1 in Experiment 2, changes the magnetic flux associated with coil C_1 . This change in magnetic flux induces emf in coil C_1 . It was this induced emf which caused electric current to flow in coil C_1 and through the galvanometer.

Experiment 3: When the tapping key K is pressed, the current in coil C_2 (and the resulting magnetic field) rises from zero to a maximum value in a very short time. Consequently, the magnetic flux through the neighboring coil C_1 also increases. It is the change in magnetic flux through coil C_1 that produces an induced emf in coil C_1 .

When the key is held pressed, current in coil C_2 becomes constant. Therefore, there is no change in the magnetic flux through coil C_1 and the current in coil C_1 drops to zero.

When the key is released, the current in C_2 and the resulting magnetic field decreases from the maximum value to zero in a very short time. These results in a decrease in magnetic flux through coil C_1 and hence this change again induces an electric current in coil C_1 .

THINK ABOUT THESE

- **In experiment 3 the moment we press the key to allow flow of current in coil C_2 , the magnetic field would develop around the coil due to current in the coil C_2 . Would the coil have a changing magnetic field around itself?**
- **In experiment 3 if we switch the current and switch it off to allow flow of current in coil C_2 and then stop the current in it. The magnetic field would develop around the coil due to current in the coil C_2 . Would the coil have a changing magnetic field**

around itself both when we switch ‘on’ the current and when we switch ‘off’ the current?

From the above observations we can conclude that

a change of magnetic flux through a circuit induces emf in it.

Faraday stated his experimental observations in the form of a law called Faraday’s laws of electromagnetic induction.

10. FARADAY’S LAWS OF ELECTROMAGNETIC INDUCTION

First law: It states that whenever the magnetic flux linked with a coil changes with time, an emf is induced in the coil. The induced emf lasts in the coil only as long as the change in the magnetic flux continues.

The induced emf causes a current flow in the conductor, in a closed wire loop current flows. This current can be measured using current meters

Second law: It states that the magnitude of the emf induced in the coil is directly proportional to the time rate of change, of the magnetic flux linked with the coil.

The second law can be concluded from the observation that when the magnet or the current carrying coil was moved at a faster rate towards or away from the coil C_1 , the galvanometer shows more deflection i.e. The induced emf is more. Hence, the magnitude of the emf induced in the coil, the time rate of change of the magnetic flux linked with the coil.

Mathematically, the induced emf is given by

$$e = - \frac{d\Phi_B}{dt}$$

The **negative sign indicates the direction of induced emf, e** and hence the direction of induced current in a closed loop.

In the case of a **closely wound coil of N turns**, change of flux, associated with each turn, is the same. Therefore, **the expression for the total induced emf is given by:**

$$e = - \frac{Nd\phi_B}{dt}$$

Negative sign is taken because induced emf always tends to oppose any change in the magnetic flux associated with the circuit. **This formulates the Lenz's law, which will be discussed in module 2.**

ANSWER THE FOLLOWING:

- **A closed loop is held stationary in the magnetic field between the north and south poles of a horse-shoe permanent magnet . Can we hope to generate a current in the loop by using very strong magnet?**

Answer: As there **is no change in magnetic flux associated with the loop there will be any current generated in the loop.** Even if a strong magnet is used there will be no changing magnetic field hence magnetic flux will be constant and no induced emf will be there.

- **A closed loop moves normal to constant electric field between the plates of a large capacitor. Is a current induced in the loop:**
 - When it is wholly inside the region between the capacitor plates**
 - When it is partially outside the plates of the capacitor? The electric field is normal to the plane of the loop.**

Answer: In both the cases:

(i) and (ii) there will be no emf that will be induced as induction does not take place due to changing electric field, it takes place due to changing magnetic field.

- **A rectangular loop and a circular loop are moving out of a uniform magnetic field region to a field-free region with a constant velocity v . In which loop do you expect the induced emf to be constant during the passage out of the field region? The field is normal to the loops.**

Answer : The induced emf will be constant in the rectangular loop and not in circular loop. This is so because the rate of change of area is constant for rectangular loop and not for circular loop.

EXAMPLE

Consider Experiment 1,2 and 3

- (a) **What would you do to obtain a large deflection of the galvanometer?**
- (b) **How would you demonstrate the presence of an induced current in the absence of a galvanometer?**

SOLUTION

(a) To obtain a large deflection, one or more of the following steps can be taken:

- (i) Use a rod made of soft iron inside the coil C_2 ,
- (ii) Connect the coil to a powerful battery, and move the arrangement rapidly towards the test coil C_1 .

(b) Replace the galvanometer by a small bulb, the kind one finds in a small torch light. The relative motion between the two coils will cause the bulb to glow and thus demonstrate the presence of an induced current.

In experimental physics one must learn to innovate. Michael Faraday who is ranked as one of the best experimentalists ever, was legendary for his innovative skills.

EXAMPLE

A square loop of side 10 cm and resistance 0.5Ω is placed vertically in the east-west plane. A uniform magnetic field of 0.10 T is set up across the plane in the north-east direction. The magnetic field is decreased to zero in 0.70 s at a steady rate. Determine the magnitudes of induced emf and current during this time-interval.

SOLUTION

The angle θ made by the area vector of the coil with the magnetic field is 45° .

The initial magnetic flux is

$$\phi = \mathbf{B A} \cos \theta = \frac{0.1 \times 10^{-2}}{\sqrt{2}} \text{ Wb}$$

Final flux (minimum) = 0

This change in flux takes place in 0.7 s hence the magnitude of induced emf will be

$$e = \frac{\Delta \phi}{\Delta t} = \frac{(\phi - 0)}{\Delta t} = \frac{10^{-3}}{\sqrt{2} \times 0.7} = 1.0 \text{ mV}$$

The magnitude of induced current will be

$$I = \frac{e}{R} = \frac{10^{-3} \text{ V}}{0.5 \text{ ohm}} = 2 \text{ mA}$$

Note;

The induced current depends upon the conductor resistance, so for the same induced emf we may get different values of induced current.

The earth's magnetic field also produces a flux through the loop, but it is steady field which does not change within the time span of the experiment and therefore will not induce any emf.

EXAMPLE

A circular coil of radius 10 cm, 500 turns and resistance 2Ω is placed with its plane perpendicular to the horizontal component of the earth's magnetic field. It is rotated about its vertical diameter through 180° in 0.25 s. Estimate the magnitudes of the emf and current induced in the coil. Horizontal component of the earth's magnetic field at the place is $3.0 \times 10^{-5} \text{ T}$.

SOLUTION

Initial flux through the coil

$$\Phi(\text{initial}) = B A \cos 0 = 3.0 \times 10^{-5} \times (\pi \times 10^{-2}) \times \cos 0 = 3\pi \times 10^{-7} \text{ Wb}$$

$$\Phi(\text{final}) = B A \cos 180 = 3.0 \times 10^{-5} \times (\pi \times 10^{-2}) \times \cos 180 = -3\pi \times 10^{-7} \text{ Wb}$$

$$\text{Induced emf } = e = -N \frac{\Delta\Phi}{\Delta t} = 500 \times (6\pi \times 10^{-7}) / 0.25$$

$$= 3.8 \times 10^{-3} \text{ V}$$

$$I = \frac{e}{R} = 1.9 \times 10^{-3} \text{ A}$$

Note that the magnitudes of ε and I are the estimated values. Their instantaneous values are different and depend upon the speed of rotation at the particular instant.

TRY THESE

- A horizontal straight wire 10 m long extending from east to west is falling with a speed of 5.0 m s^{-1} , at right angles to the horizontal component of the earth's magnetic field, $0.30 \times 10^{-4} \text{ Wb m}^{-2}$.
 - (a) What is the instantaneous value of the emf induced in the wire?
 - (b) What is the direction of the emf?
 - (c) Which end of the wire is at the higher electrical potential?
- A jet plane is travelling towards west at a speed of 1800 km/h. What is the voltage difference developed between the ends of the wing having a span of 25 m, if the Earth's magnetic field at the location has a magnitude of $5 \times 10^{-4} \text{ T}$ and the dip angle is 30° .

11. SUMMARY

- **Electromagnetic Induction:** The phenomenon, in which an induced emf is generated by a varying magnetic field, is called electromagnetic induction (EMI).
- **Magnetic flux:** Just like electric flux, magnetic flux Φ_B through any surface of area A held in a magnetic field \mathbf{B} is given by the total number of magnetic field lines crossing normally through the area. Mathematically, it is equal to the dot product of \mathbf{B} and \mathbf{A} .

$$\Phi_B = \mathbf{B} \cdot \mathbf{A} = BA \cos \theta, \text{ where } \theta \text{ is the angle between } \mathbf{B} \text{ and } \mathbf{A}$$

- **Induced emf and Induced current:** The emf developed in the loop when the magnetic flux associated with it changes is called induced emf; when the conductor is in the form of a closed loop, the current induced in the loop, is called induced current.
- **Weber:** One weber is defined as amount of magnetic flux over an area of 1 m^2 held normal to a uniform magnetic field of one Tesla. The SI unit of magnetic flux is weber (Wb) or tesla meter square (Tm^2).

- Faraday's laws of electromagnetic induction:

First law: It states that whenever the amount of magnetic flux linked with the coil changes, an emf is induced in the coil. The induced emf lasts in the coil so long as the change in the magnetic flux continues.

Second law: It states that the magnitude of the emf induced in the coil is directly proportional to the rate of change of the magnetic flux linked with the coil.